

# MOBILE WORK PLATFORM

200 KG  
SWL\*

IDEAL FOR INDUSTRIAL PLANT MAINTENANCE/ MODULAR WORK

## Product Features:

- Heavy Duty Aluminium profile construction, gives durability, agility and great load bearing capacity.
- Reinforced aluminium platform, provides comfortable access during long working hours.
- Standard 60° angle, wide step (depth and width) allow effortless ascent/descent.
- Three sided guardrail, with safety chain locking for maximum protection.
- Fully welded solution; the handrails and guardrails can be dismantled.
- Handrail for assisted climb.
- Additional features possible (i.e. toe plate, door, etc).



Product Dimensions

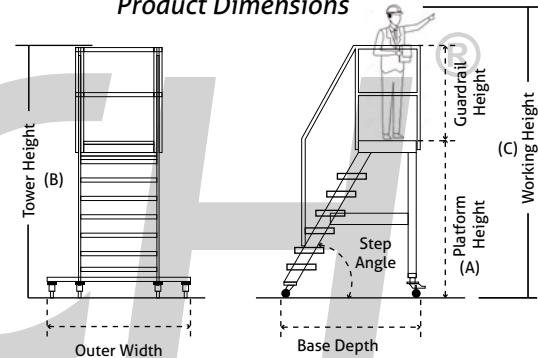

Working Platform

Step and Wheel

Side View



## Table of Measurements:

MOBILE WORK PLATFORM					
ITEM CODE	STEPS + PLATFORM	PLATFORM HEIGHT (A)	TOWER HEIGHT (B)	WORKING HEIGHT (C)	BASE DEPTH
MWP 2	1+1	500 MM	1475 MM	2500 MM	800 MM
MWP 3	2+1	750 MM	1725 MM	2750 MM	960 MM
MWP 4	3+1	1000 MM	1975 MM	3000 MM	1100 MM
MWP 5	4+1	1250 MM	2225 MM	3250 MM	1250 MM
MWP 6	5+1	1500 MM	2475 MM	3500 MM	1390 MM
MWP 7	6+1	1750 MM	2725 MM	3750 MM	1668 MM

Above table based on standard dimensions.

## Product Code: MWP

### Standard Dimensions:

Step interval: 250mm  
 Step width\*\*: 600mm (800mm option available)  
 Step depth: 180mm  
 Step angle: 60°  
 Platform dimensions\*\*: 600mm (width) x 600mm (depth)  
 Toeboard option available

Ladder outer width: approx 700mm  
 Guardrail height: approx 975mm  
 Handrail height: based of step angle

\* SWL may vary based on final platform dimensions.  
 \*\* Indicates options that may or may not be altered.